



# PMC-220 Quick Start Guide

## Package Contents

- PMC-220 Meter
- 1x120Ω Termination Resistor
- Quick Start Guide (This document)

## Overview

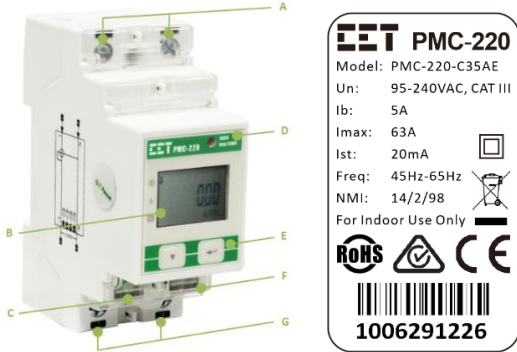

**EET PMC-220**  
 Model: PMC-220-C35AE  
 Un: 95-240VAC, CAT III  
 Ib: 5A  
 Imax: 63A  
 Ist: 20mA  
 Freq: 45Hz-65Hz  
 NMI: 14/2/98  
 For Indoor Use Only

RoHS CE

1006291226

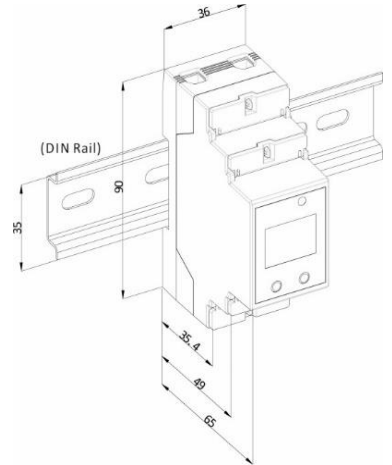
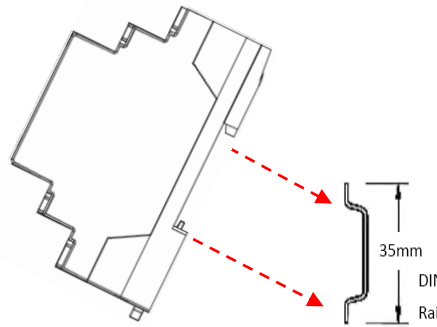

	Terminals	Description
A	1, 2	L, N from Source
B	N/A	LCD Display
C	5, 6	Pulse Output (E+, E-)
D	N/A	LED Pulse Output
E	N/A	Buttons
F	7, 8	RS-485 (D+, D-)
G	3, 4	L', N' to Load

Front View of PMC-220

Meter Installation

## Installation steps

- The PMC-220 should be installed in a dry environment with no dust and kept away from heat, radiation and electrical noise source
- Before installation, make sure that the DIN rail is already in place
- Move the installation clip at the back of the PMC-220 downward to the “unlock” position
- Mount the PMC-220 on the DIN rail following the method below
- Push the installation clip upward to the “lock” position to secure the PMC-220 on to the DIN Rail

## RS-485 Wiring

- The PMC-220 provides one standard RS-485 port and supports the Modbus RTU protocol. Up to 32 devices can be connected on a RS-485 bus. The overall length of the RS-485 cable connecting all devices should not exceed 1200m.
- If the master station does not have a RS-485 communications port, a RS-232/RS-485 or USB/RS-485 converter with optically isolated outputs and surge protection should be used.
- Each PMC-220 comes with a 120Ω Termination Resistor. It is recommended that a single termination resistor be used at the end of the RS-485 bus to prevent signal reflection.

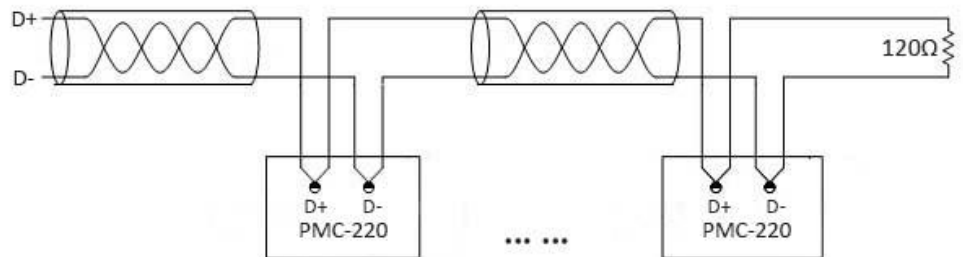
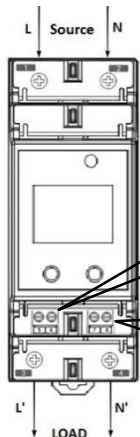

Wiring Connections



# PMC-220 Quick Start Guide

## Using the Front Panel Buttons

Buttons	Data Display Mode	Setup Configuration Mode
<▼>	<ol style="list-style-type: none"> <li>While in the <b>Energy Measurements</b> menu, pressing this button scrolls through the following measurements: kWh Imp, kWh Exp, kvarh Imp, kvarh Exp and kVAh.</li> <li>While in the <b>Basic Measurements</b> menu, pressing this button scrolls through the following measurements: U, I, kW, kvar, kVA, PF and Frequency.</li> <li>While in the <b>Programming Counters</b> menu, pressing this button scrolls through the following counters: Front Panel Programming Counter (FCnT) and Communication Programming Counter (CCnT)</li> </ol>	<ol style="list-style-type: none"> <li>“—Prog—” is displayed when the <b>Setup Configuration</b> mode is first entered.</li> <li>Before an item is selected, pressing this button scrolls to the next setup parameter. If the selected parameter is a numeric value, pressing this button increments the selected digit.</li> <li>If the selected parameter is an enumerated value, pressing this button scrolls through the enumerated list.</li> </ol>
<↔>	<ol style="list-style-type: none"> <li>Pressing this button momentarily toggles between the <b>Energy Measurements, Basic Measurements and Programming Counters</b> menus.</li> <li>Holding down this button for 2 seconds toggles between the <b>Data Display and Setup Configuration</b> modes.</li> </ol>	<ol style="list-style-type: none"> <li>Holding down this button for 2 seconds toggles between <b>Data Display</b> and <b>Setup Configuration</b> modes.</li> <li>Once inside the <b>Setup Configuration</b> mode, pressing this button selects a parameter for modification.</li> <li>Once a parameter is selected, its value blinks when it's to be modified. Pressing button again will save the current value into memory.</li> <li>If the selected parameter is a numeric value, pressing this button momentarily moves the cursor one position to the left. Once the left-most digit is reached, pressing this button again will save the current value into memory.</li> <li>Holding this button down for two seconds will return to the <b>Data Display</b> mode.</li> </ol>

## Setup Parameters

Menu	Parameters	Description	Range/Options	Default
PROG	Programming	Setup Configuration Mode	/	/
PW	Password	Enter Password	0 to 9999	“0”
SET PW	Set Password	Enter New Password	0 to 9999	“0”
Id	Unit ID	COM Unit ID	1 to 247	Last 2 digits of S/N
bd	Baud Rate	Data rate in bits per second	1200/2400/4800/9600/19200	9600
CFG	COM Port Configuration	Data Format	8N2/8O1/8E1/8N1	8E1
PULSE	Energy Pulsing	Enable Energy Pulsing	YES/NO	YES
CLr En	Clear Energy	Clear Energy	YES/NO	NO
CLr Cnt	Clear Counters	Clear both the FP and Comm. Programming Counters	YES/NO	NO
FW	Firmware Version	Firmware Version	e.g. 10002 means V1.00.02	/
ProT	Protocol	Protocol Version	e.g. 1.1 means means V1.1	/



## Danger

Failure to observe the following instructions may result in severe injury or death and/or equipment damage.

- Installation, operation and maintenance of the meter should only be performed by qualified, competent personnel with appropriate training and experience with high voltage and current devices. The meter must be installed in accordance with all local and national electrical codes.
- Ensure that all incoming AC power and other power sources are turned OFF before performing any work on the meter.
- Before connecting the meter to the power source, check the label on top of the meter to ensure that it is equipped with the appropriate power supply, and the correct voltage and current input specifications for your application.
- During normal operation of the meter, hazardous voltages are present on its terminal strips and throughout the connected potential transformers (PT) and current transformers (CT). PT and CT secondary circuits are capable of generating lethal voltages and currents with their primary circuits energized. Follow standard safety precautions while performing any installation or service work (i.e. removing PT fuses, shorting CT secondaries, ...etc).
- Do not use the meter for primary protection functions where failure of the device can cause fire, injury or death. The meter should only be used for shadow protection if needed.
- Under no circumstances should the meter be connected to a power source if it is damaged.
- To prevent potential fire or shock hazard, do not expose the meter to rain or moisture.
- Setup procedures must be performed only by qualified personnel familiar with the instrument and its associated electrical equipment.
- DO NOT open the instrument under any circumstances.